

AIR KNIFE INSTALLATION & MAINTENANCE

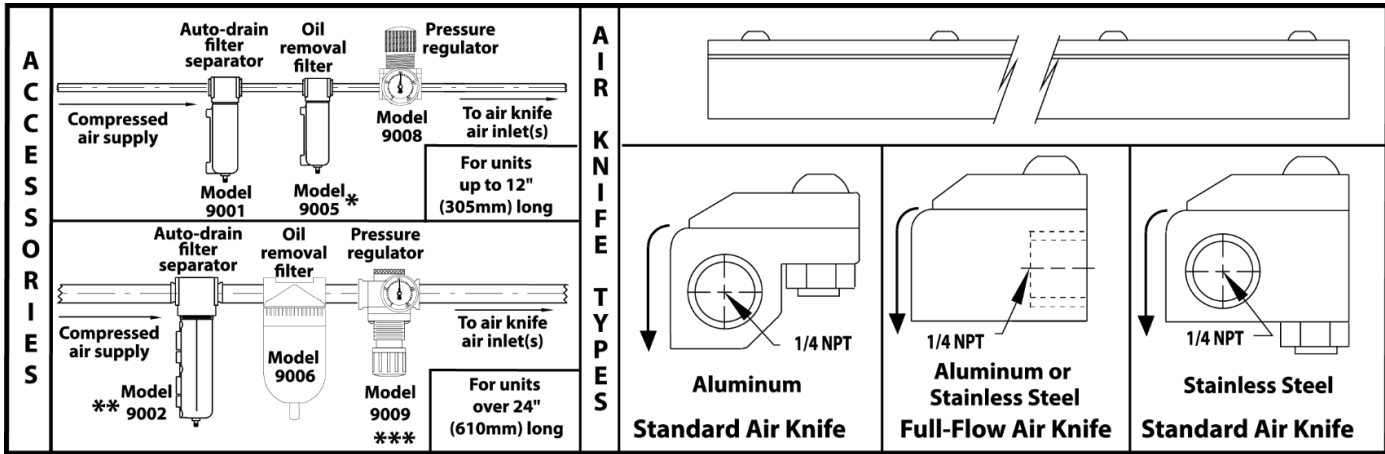

- * Use Model 9006 Oil Removal Filter for Air Knives longer than 9" (229mm)
- ** Use Model 9032 Auto Drain Filter with 18" to 24" (457-610mm) Air Knives
- *** Use Model 9033 Pressure Regulator with 18" to 24" (457-610mm) Air Knives

COMPRESSED AIR LINE SIZES

Compressed air lines should be sized to hold pressure drops to a minimum. Do not use restrictive fittings or undersized lines that can "starve" the Air Knife by causing excessive line pressure drop.

The following table (below right) shows the recommended infeed pipe sizes. If compressed air hose is used, always go one size larger than the recommended pipe size due to the smaller I.D. of hose. (Example: Consider 1/2" I.D. hose the equivalent of 3/8" pipe.)

For 24" (610mm) and longer Air Knives, it is best to supply both ends. The standard gap setting is .002" (0.05mm). For larger gap settings, it is best to supply both ends of the Air Knife in order to maintain uniform flow. (see Air Knife Shim Set)

AIR KNIFE RECOMMENDED INFEED PIPE SIZES

Single Air Knife Installation

Air Knife Length	Model Numbers	Infeed Pipe Size Length of Run		
		10' (3m)	50' (15.2m)	100' (30.5m)
3" (76mm)	2003, 2003SS, 2603, 2603SS	1/4"	3/8"	1/2"
6" (152mm)	2006, 2006SS, 2606, 2606SS	1/4"	3/8"	1/2"
9" (229mm)	2009, 2009SS, 2609, 2609SS	3/8"	1/2"	3/4"
12" (305mm)	2012, 2012SS, 2612, 2612SS	3/8"	1/2"	3/4"
18" (457mm)	2018, 2018SS, 2618, 2618SS	1/2"	3/4"	1"
24" (610mm)	2024, 2024SS, 2624, 2624SS	1/2"	3/4"	1"
30" (762mm)	2030, 2030SS, 2630, 2630SS	3/4"	1"	1"
36" (914mm)	2036, 2036SS, 2636, 2636SS	3/4"	1"	1-1/4"
42" (1067mm)	2042, 2042SS	1"	1-1/4"	1-1/4"
48" (1219mm)	2048, 2048SS	1"	1-1/4"	1-1/4"

MANIFOLD AND AIR KNIFE RECOMMENDED INFEED PIPE SIZES

Multiple Air Knife Installation

Web Width	Min. Manifold Size	Infeed Pipe Size Length of Run		
		10' (3m)	50' (15.2m)	100' (30.5m)
60" (1.5M)	1"	1"	1-1/4"	1-1/4"
84" (2.13M)	1"	1"	1-1/4"	1-1/2"
102" (2.6M)	1-1/4"	1-1/4"	1-1/4"	1-1/2"
120" (3M)	1-1/4"	1-1/4"	1-1/2"	2"

MANIFOLD SYSTEMS

Sometimes, a long continuous sheet of air is needed. When the required length exceeds the standard Air Knife lengths, they can be manifolded. Stagger the Air Knives front to back, or top to bottom. The table (above right) shows the recommended manifold sizes for various web lengths.

COMPRESSED AIR SUPPLY

With proper filtration and separation of dirt, moisture and oil from the compressed air supply, the Air Knife will operate for years with no maintenance required.

Use a 5 micron or smaller filter separator on the compressed air supply. Use Model 9001 Automatic Drain Filter Separator for units up to 12" (305mm), Model 9032 for 18" (457mm) and 24" (610mm) units and Model 9002 for units larger than 24" (610mm). To prevent problems associated with oil, use an oil removal filter. Use a 0.03 micron or smaller oil removal filter on the compressed air supply. Use Model 9005 Oil Removal Filter for units up to 6" (152mm), Model 9006 Oil Removal Filter for units longer than 9" (229mm). The oil removal filter should be used downstream from the automatic drain filter separator. Filters should be used close to each Air Knife, within 10 to 15' (3 to 4.6m) is best. The Air Knife is designed to use normal shop air supplies up to 100 PSIG (6.9 BAR, 689 kPa). For infinite control of flow and force, pressure may be regulated. Use Model 9008 Pressure Regulator for lengths up to 12" (305mm), Model 9033 Pressure Regulator for 18" & 24" (457 & 610mm) and Model 9009 Pressure Regulator for lengths over 24" (610mm). Air Knives are designed for 250 PSIG (17.2 BAR, 1.72 MPa) Max.

If air preparation units other than EXAIR models are being used, please note the following:

- **PRESSURE REGULATORS** – Must be pressure relieving and rated for a supply pressure of 250 PSIG (17.2 BAR, 1.72 MPa). Suggested operating pressure is 5-125 PSIG (0.3-8.6 BAR, 34-862 kPa). For models 12" (305mm) and under, flow should be minimum 50 SCFM (1,416 SLPM). For models over 12" (305mm) and up to 24" (610mm), flow should be minimum 90 SCFM (2,549 SLPM). For models over 24" (610mm), flow should be minimum 185 SCFM (5,239 SLPM).
- **AUTO DRAIN FILTER SEPARATORS** – Must be rated for a supply pressure of 250 PSIG (17.2 BAR, 1.72 MPa) and have 5 micron filtration. For models 12" (305mm) and under, flow should be minimum 50 SCFM (1,416 SLPM). For models over 12" (305mm) and up to 24" (610mm), flow should be minimum 90 SCFM (2,549 SLPM). For models over 24" (610mm), flow should be minimum 185 SCFM (5,239 SLPM).
- **OIL REMOVAL FILTERS** – Must be rated for a supply pressure of 250 PSIG (17.2 BAR, 1.72 MPa) and have 0.03 micron filtration. For models 6" (152mm) and under, flow should be minimum 37 SCFM (1,048 SLPM). For models over 6" (152mm), flow should be minimum 185 SCFM (5,239 SLPM).

USING THE AIR KNIFE

The Model 9060 Universal Air Knife Mounting System (included in deluxe kits or sold separately) can be articulated into any position to provide secure, precise positioning for any air knife. The air knife can also be supported by the compressed air pipe or by using the existing bolts (be sure to retighten to 7.5 foot-pounds for standard air knives and 22 inch-pounds for full-flow air knives for proper performance).

The force (combination of mass flow and velocity) of an Air Knife is reasonably constant up to a 12" (305mm) distance. Force is lower at distances greater than 12" (305mm). However, many applications are successful at 18" (457mm), 24" (610mm) or more.

To increase force, shims may be added to the Air Knife. This will increase mass flow, velocity, and compressed air consumption. See the catalog or website for ordering shim sets.

The high velocity air stream thickens as it flows away from the Air Knife. At 6" (152mm), it is 2-1/2" (64mm) thick and at a 12" (305mm) distance, 5" (127mm) thick. If the application requires a thin "knife" of air, mount the Air Knife close. This gives a high velocity, thin sheet of air that has lower mass flow. As the distance from the product surface to the Air Knife increases, the thickness of the sheet of air increases, velocity decreases and mass flow increases. By moving the Air Knife up and down, the optimum operating distance may be determined.

Note: Sharp edges might be present on any of these products. Please take appropriate precautions when handling.

AIR KNIFE SHIM SET

Force and flow through the Air Knife may be easily increased by adding shims to open the air gap. The Air Knife is supplied with a .002" (0.05mm) thick shim installed. It sets the air slot to a .002" (0.05mm) opening. To increase the air gap, use a shim set (shim set is not included with the Air Knife). Aluminum Standard and Full-Flow Shim Sets include shims of .001" (0.03mm), .003" (0.08mm) and .004" (0.10mm) thickness. Stainless Steel Standard Air Knife Shim Sets include (3) .002" (0.05mm) thick shims. Stainless Steel Full-Flow Air Knife Shim Sets include (1) .002" (0.05mm) thick shim. By changing and stacking them, gaps may be set from .001" to .010" (0.03 to 0.25mm) for aluminum Air Knives and .002" to .008" (0.05 to 0.20mm) for stainless steel. Individual shims are available.

To change shims, remove the assembly nuts and bolts. Inspect the Air Knife and shim to assure no dirt or chips are on matching surfaces or in the plenum chamber. Replace or add a shim(s) and re-assemble. For Full-Flow Air Knives retighten to 22 inch-pounds. For Standard Air Knives retighten to 7.5 foot-pounds. If the force is more than needed, regulate pressure down to match the force to the application requirements.

TROUBLESHOOTING & MAINTENANCE

If There Is A Reduction In Flow Or Force From The Air Knife, check the pressure by installing a gauge at the inlet of the Air Knife. Large pressure drops are possible due to undersized lines, restrictive fittings and clogged filter elements.

For replacement or repair filter and regulator parts, contact EXAIR at 1-800-903-9247 or techhelp@exair.com. Call (513) 671-3322 for outside the US and Canada.

CLEANING

If contaminants have clogged the Air Knife, inspect the unit by disassembling. The Air Knife consists of two component parts and between them is a shim that sets the gap the compressed air exhausts through. This shim is usually .002" (0.05mm) thick although thicker shims can be used. Inspect each part for dirt contamination and a possible oil film in the area of the slotted nozzle. Clean each part and reassemble with the shim installed in the correct position.

Occasionally, there is a buildup which occurs on the face of the Air Knife as a result of vapors in the atmosphere. Clean this surface with a solvent and a clean rag. To prevent contaminants from getting pushed back into the slot, perform this procedure with a small amount of compressed air passing through the Air Knife.

If you have any questions or problems, please contact:

YOUR INFO HERE:

Company Name

Telephone

FAX:

Email:

Website: